

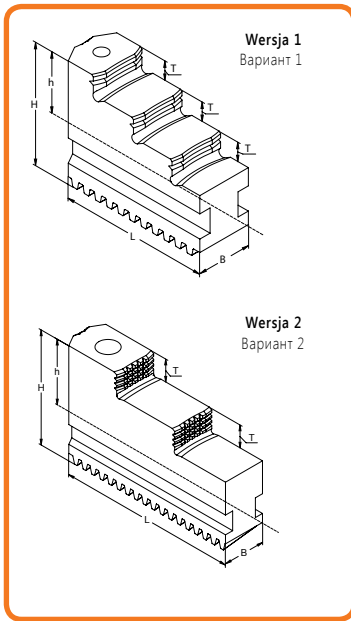

- 1
- 2
- 3
- 4
- 5
- 6
- 7
- C



SZCZĘKI JEDNOLITE TWARDE
 КУЛАЧКИ ЦЕЛЬНЫЕ КАЛЕННЫЕ

SYSTEM REISHAUER LUB FORKARDT
 СИСТЕМА REISHAUER ИЛИ FORKARDT

Nr produktu Код продукта	Typ szczęk Тип кулачков	Wersja Вариант	B	H	L	T	h	kg / kpl.	Typ ząbienia
								кг / кпл.	Тип зубчатой
398530923800	SJT 160 RHU-03	1	20	46,0	66,6	7	24	0,9	R
398530921200	SJT 160 RHU-01	1	20	44,0	58,0	7	22	0,8	R
398530922500	SJT 160 RHU-02	1	20	44,0	58,0	7	22	0,8	R
398530925300	SJT 160 F	1	20	45,0	79,0	7,5	24	1,1	F
398530933000	SJT 200 RHU-01	1	22	54,0	84,8	8	29	1,6	R
398530935500	SJT 200 F	1	22	60,0	94,0	10	35	1,9	F
398530941600	SJT 250 RHU-01	1	26	65,0	107,4	10	36	2,9	R
398530945700	SJT 250 F	2	26	70,0	115,0	14	40	3,3	F
398530951800	SJT 315 RHU-01	1	32	66,0	117,0	11	32	3,5	R
398530955900	SJT 315 F	2	32	81,0	129,0	15	46	5,4	F
398530965000	SJT 400 F	2	45	93,3	167,2	20	53	10,8	F

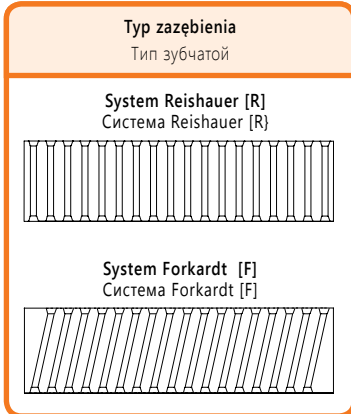

SJT F

SJT RHU