

4-BACKENFUTTER

4-JAW CHUCK

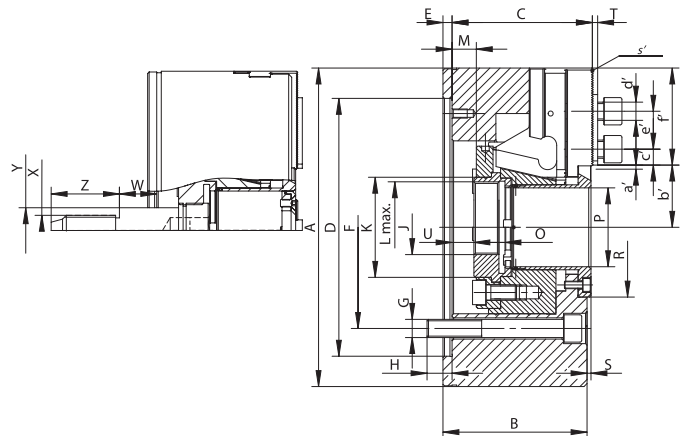

2605-K

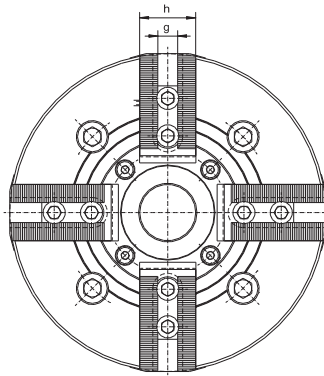

60° Verzahnung
Compatibile 60°

Lieferung inkl. Spezialeinsatz zum Umrüsten in ein Futter ohne Durchgangsbohrung
Delivery includes a special insert that enables easy transformation from a through-hole into a non through-hole

Artikelnummer	Code number	352605031000	352605040000	352605050100	352605060300	352605070500
Typ	Type	2605-135-34K	2605-160-45K	2605-200-52K	2605-250-75K	2605-315-91K
A (Größe Size)		135	169	210	254	315
B		60	81	95	106	108
C		59,5	79	93	104	106,5
D H4		110	140	170	220	220
E		4	6	6	6	6
F		82,6	104,8	133,4	171,4	171,4
G		4xM10	4xM10	4xM12	4xM16	4xM16
H		14,5	13,5	16,5	18	27
J		M20x1,5	M27x2	M36x2	M50x2	M56x2
K		45	60	66	94	108
L max.		M40x1,5	M55x2	M60x2	M85x2	M100x2
¹ M (Max. Kolbenhub)		10/0	13/-3	16/-6,5	19,5/-7,5	23/-4
O		20	19	20,5	25	28
P		34	45	52	75	91
R		56	76	92	117	134
S		1,5	2,6	2,6	2,6	0,6
T		2	3	3	3	2,5
U min.		-9,5	-5	-8	-18,5	-19
U max.		0,5	11	14,5	8,5	8
W		20,5	25,5	27,5	33	34
Z		35	40	45	55	55
X		M12	M16	M20	M24	M24
Y		20	24	30	36	36
² a' (Max. Backenhub)		2,7	3,5	5	6	6
³ Verzahnung		1,5x60°	1,5x60°	1,5x60°	1,5x60°	1,5x60°
b' min.		24	30,2	35,5	47,9	56,9
b' max.		26,8	33,7	40,5	53,9	62,9
c' min.		7	9	10,5	11,7	13,2
c' max.		20	25,5	33	41,7	60
d'		M8	M10	M12	M12	M16
e'		14	20	25	30	30
f'		40,5	51	64,5	73	94
g H7		10	12	14	16	21
h		25	38	40	45	52
⁴ Max. Betätigungskraft [daN]		1 750	2 200	3 400	4 300	5 600
⁵ Max. Gesamtspannkraft [daN]		3 600	5 700	8 600	11 100	14 400
⁶ Max. Drehzahl [U/min]		6 000	5 000	4 300	3 600	2 800
⁷ Massenträgheitsmoment [kgm ²]		0,014	0,047	0,133	0,315	0,779
⁸ Gewicht (ohne Aufsatzbacken) [kg]		5,6	12	21,5	35	56,5

¹ Max. drawbar stroke

⁵ Max. total gripping force [daN]

² Max. jaw stroke

⁶ Max. speed [rpm]

³ Serration

⁷ Moment of inertia [kgm²]

⁴ Max. pulling force [daN]

⁸ Weight (without top jaws) [kg]