

# AUFSPANNPLATTE 4200

## FACE PLATE 4200



### AUFSPANNPLATTE

### FACE PLATE

#### EIGENSCHAFTEN: FEATURES:

- Mit zusätzlichen T-Nuten ab Ø 1000 mm  
Additional T-slots in dimensions up to 1000 mm
- Erhältlich mit A, C & D Spindel-Befestigungen  
Available with A, C & D mount type
- Gusskörper  
Cast iron body

#### APPLICAZIONE: UTILISATION:

- Einsetzbar beim Drehen, Bohren, Reiben und Fräsen von asymmetrischen Werkstücken  
Used in turning, drilling, reaming and milling of irregular shaped workpieces
- Direktmontage auf der Spindelnase  
Direct mounting on the spindle nose
- Indirekte Montage auf der Spindelnase durch die Adapterflansche  
Indirect mounting on the spindle nose through the adapter plate
- Nach Ihren Wünschen maßgeschneidert bestellbar  
Made to order according to customer specifications

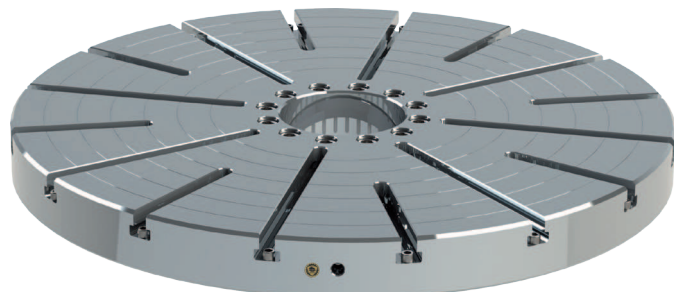

400 - 1000 mm

1250 - 1500 mm

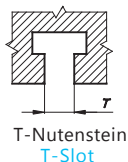
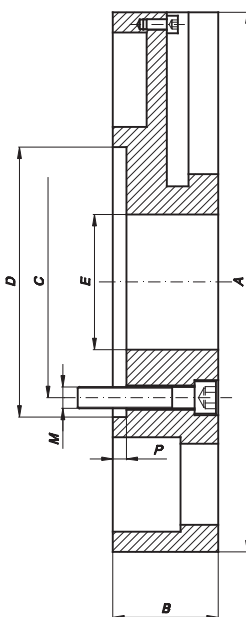
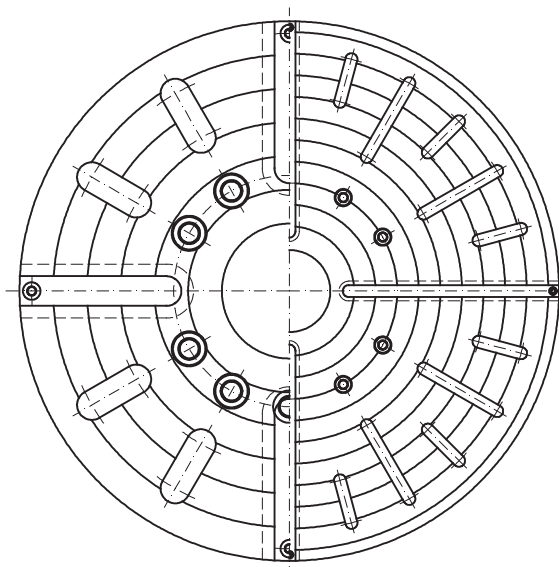

Artikelnummer	Bezeichnung	A	B	C	D	E	M	P	T	Kurzkegel			
Code number	Type									Short taper			
354200040400	4200 - 400	400	78	171.4	200	100	M18	10	18	6	8	11	15
354200050600	4200 - 500	500	78	235	270	125	M22	12	22	6	8	11	15
354200060800	4200 - 630	630	80	235	270	160	M22	12	22	8	11	15	
354200080100	4200 - 800	800	85	330.2	380	200	M26	12	22	8	11	15	
354200090300	4200 - 915	915	85	330.2	370	190	M26	18	22	8	11	15	
354200100800	4200 - 1000	1000	90	330.2	370	190	M26	18	28	11	15	20	
354200200900	4200 - 1250	1250	90	500	550	190	M26	18	28	11	15	20	
354200400000	4200 - 1400	1400	95	500	550	190	M26	18	28	11	15	20	
354200500100	4200 - 1500	1500	95	500	550	190	M26	18	28	11	15	20	